

SSI ABSOLUTE SINGLETURN ENCODERS, CHM9 RANGE

Especially designed for heavy-duty (steel, paper, wood – mills, cranes ...) Compact and robust conception. Excellent resistance to shocks/vibrations and to extreme axial/radial loads



Also available in parallel output and fieldbus interface : CanOpen, DeviceNet, Profibus



CHM9_11 connection C6 or C8 (radial or axial M23)

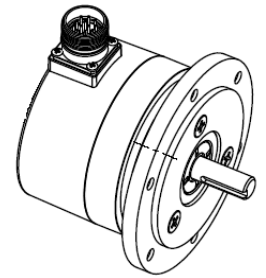
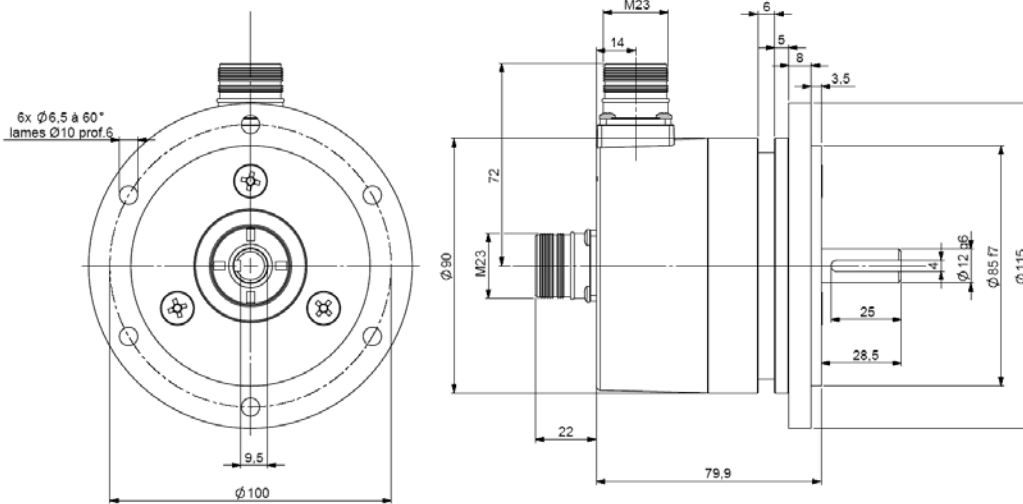

CHM9_12 connection C7R (radial cable)

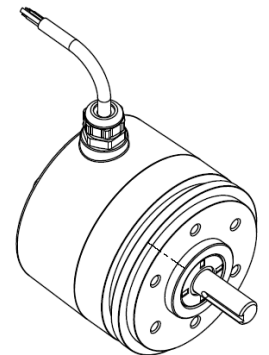
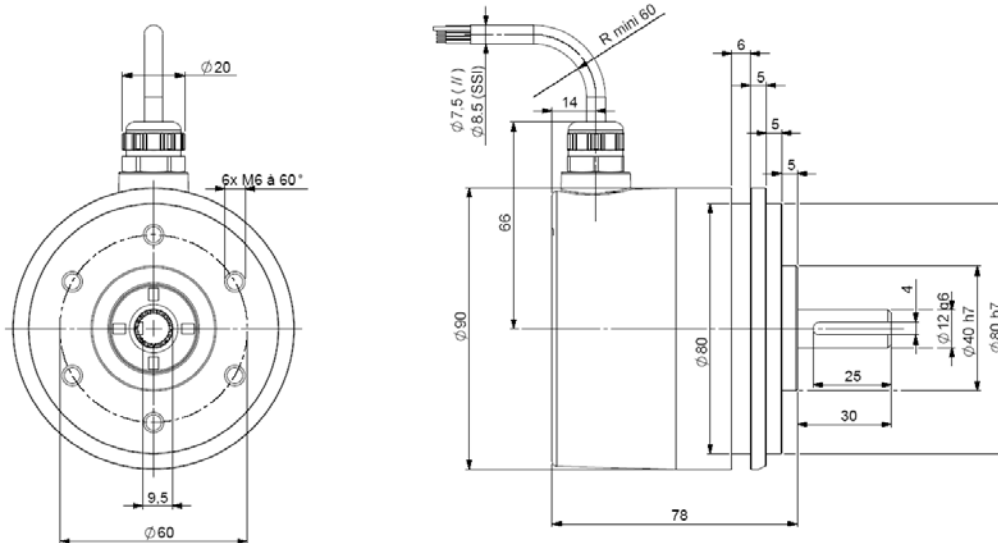

Material	Cover : zinc alloy
Stainless steel option	Body : aluminium
Shaft material	Stainless steel
Bearings	6001 serie
Maximal loads	Axial : 100 N
	Radial : 200 N
Shaft inertia	≤ 15.10 ⁻⁶ kg.m ²
Torque	≤ 10.10 ⁻³ N.m
Permissible max. speed	9 000 min ⁻¹
Continuous max. speed	6 000 min ⁻¹
Shaft seal	Viton double lips
Shocks (EN60068-2-27)	≤ 500 m.s ⁻² (during 6ms)

Vibrations (EN60068-2-6)	≤ 200 m.s ⁻² (10 ... 1 000 Hz)	
EMC	EN 50081-1, EN 61000-6-2	
Isolation	1 000 Veff	
Encoder weight (approx)	1,100kg zinc alloy cover, alu body	
	2,400kg zinc alloy cover, stainless steel body	
Encoder weight (approx)	2,600kg stainless steel cover and body	
Operating temperature	- 20 ... + 90 °C (encoder T°)	
Storage temperature	- 30 ... + 95 °C	
Protection(EN 60529)	IP 67 (cable), IP 66 (connector)	
Theoretical mechanical lifetime 10 ⁹ turns (F _{axial} / F _{radial})		
20 N / 30 N	50 N / 100 N	100 N / 200 N
360	18	2,2

SSI ABSOLUTE SINGLETURN ENCODERS, CHM9 RANGE

ELECTRICAL CHARACTERISTIC

Input signal clock CLK	per opto-coupleur
Output signal DATA	line - driver RS422
Clock frequency CLK	100kHz – 1MHz
Precision	+ ½ LSB (13 bits)

Power supply	11 – 30Vdc
Introduction	< 1 s
Consumption without load	100mA max

SSI TRANSMISSION (n=13 bits)

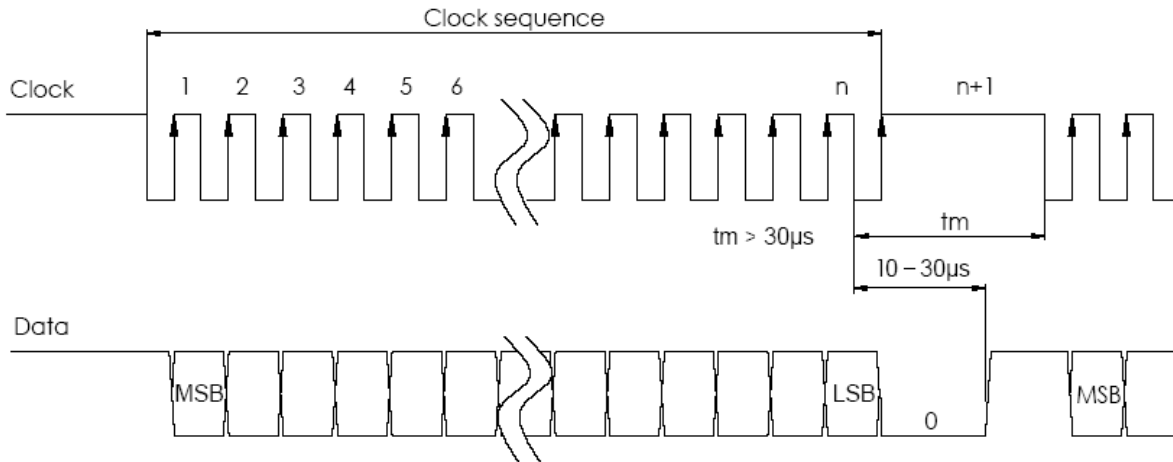

Transmission	Transmission up to 400m at 100kHz in function of cable characteristics
Cable	High security of transmission by using shielded cable and twisted pairs

* Consult us for length > 100m

STANDARD SSI CONNECTION

Type	Vcc	Gnd	Clk+	Data+	Data-	Clk-	DIRECTION
C6	1	2	3	4	6	7	9
C7	BN brown	WH white	GN green	GY grey	PK pink	YE yellow	RD red
C8	8	1	3	2	10	11	5

DIRECTION :

- CW increasing code: DIRECTION to 0V
- CCW increasing code : DIRECTION to +Vcc

ORDERING CODE (Special versions upon request, for ex. special flanges/electronics/connections...)

	Shaft Ø	Supply	Output stage	Code	Resolution	Connection	Connection orientation			
CHM9 Cover : zinc Body : alu	11 : 11mm 12 : 12mm	5 : 11 to 30Vdc	CS : SSI without parity CP : SSI even parity CI : SSI odd parity	B : Binary G : Gray	13 : 13bits	C6 : M23 12 pins CW for SSI C8 : M23 12 pins CCW for SSI	R : radial A : axial			
C7 : PE + SSI cable							Example : R020 : radial 2m cable A020 : axial 5m cable			
CBM9 Cover : zinc Body : stainless steel						CXM9 Stainless steel cover & body	CHM9	-	12 //	5

Made in FRANCE